



**G5.2W, G5, G2.2W, G2  
A4.2W, A4, A1.2W, A1  
A1.1  
SERIES**

**VEHICLE SECURITY SYSTEM  
WITH REMOTE START  
PRODUCT MANUAL**

## LIMITED LIFETIME WARRANTY

This vehicle security system is warranted to the original purchaser, to be free from defects in material and workmanship. The manufacturer will repair or replace at its option, and free of charge for the first twelve (12) months, any part that proves defective in material or workmanship under normal installation, use, and service, provided the product is returned to the manufacturer freight prepaid. After the first 12 month warranty period there will be a maximum service charge of \$50.00 per calendar year (if required) for repair and/or replacement of any defective parts.

**A copy of the original purchase and installation receipt must accompany any products returned for warranty service.** Warranty is limited to defective parts and/or replacement parts only and excludes any incidental, and consequential damages connected therewith.

The manufacturer of this theft deterrent system makes no warranty against the theft of the vehicle or its contents. This warranty is not to be construed as an insurance policy against loss.

WARRANTY OF INSTALLATION LABOR, REMOVAL AND RE-INSTALLATION CHARGES ARE NOT THE RESPONSIBILITY OF THE MANUFACTURER.

**Note: This Warranty is voided if the product was not installed by an Authorized ScyTek Dealer.**

# Table of Contents

1.	About Your System	Page 1
2.	Remote Transmitters	Page 2
	Remote Transmitter Description	Page 3
	Adding/Replacing Transmitters	Page 4
	Two Car Operation	Page 4
	Battery Replacement	Page 4
	2-way LCD Remote Transmitter Description	Page 5
	Adding/Replacing 2-way Transmitters, Programmable features and descriptions.	Page 5-8
	LCD Transmitter Battery Replacement	Page 5
3.	System Operation	Page 9
	Remote Arming*/Locking	Page 9
	Remote Disarming*/Unlocking	Page 9
	Tamper Alert*	Page 10
	Silent Arming*/Locking -Disarming*/Unlocking	Page 10
	Passive Arming*	Page 10
	Panic Mode	Page 12
	Emergency Override*	Page 12
	Optional Coded Emergency Override*	Page 12
	Automatic Rearming*	Page 12
	Valet Mode/ Driver Calling Feature	Page 12
4.	Remote Start Features	Page 13
	Remote Starting	Page 13
	Shut Down	Page 13
	Quick Stop	Page 13
	Automatic Start Mode	Page 14
	Turbo Timer Feature	Page 14
	Manual Transmission Remote Starting	Page 15
5.	Extended Features	Page 16
	Ignition Door Locking	Page 16
	Ignition Door Unlocking	Page 16
	Dome Light Activation	Page 16
	Auxiliary Function Outputs	Page 16
	Disarm with Auxiliary Function*	Page 16
	Remote Sensor Disable*	Page 16
6.	System Installation	Page 17
	Mounting the Control unit	Page 18
	Mounting the Siren*	Page 18
	Mounting the Shock Sensor*	Page 18
7.	System Wiring	Page 19
	6-Pin Starter Harness	Page 19
	20-Pin Main Harness	Page 19
	Plug-in Connectors	Page 20
8.	Jumper Settings	Page 21
	Jumper Selection	Page 21
9.	System Programming	Page 22
	Entering System Programming	Page 22
	Default Reset	Page 22
	Programmable System Options	Page 22
10.	Relay Diagrams	Page 26
11.	Door Lock Diagrams	Page 27
12.	Two Stage Door Lock Diagrams	Page 28
13.	Technical Information	Page 30
14.	System Diagnostics	Page 31
15.	Shock Sensor Adjustment.	Page 32
16.	Wiring Diagram	Back Page

# UPGRADE OPTIONS

## T5-2W-KIT

Two Way Pager upgrade kit  
Easy Plug and Play upgrade to a complete two way system.  
Increases range



## MobiLink

Smart phone upgrade  
Easy Plug and Play upgrade through the DBP (Data Bus port)  
2 Way confirmation  
Arm/Disarm  
Remote Start On/Off  
Trunk Release  
Tracking  
Alert Notification by SMS and Email

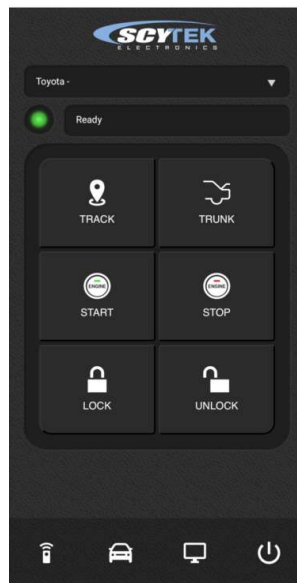
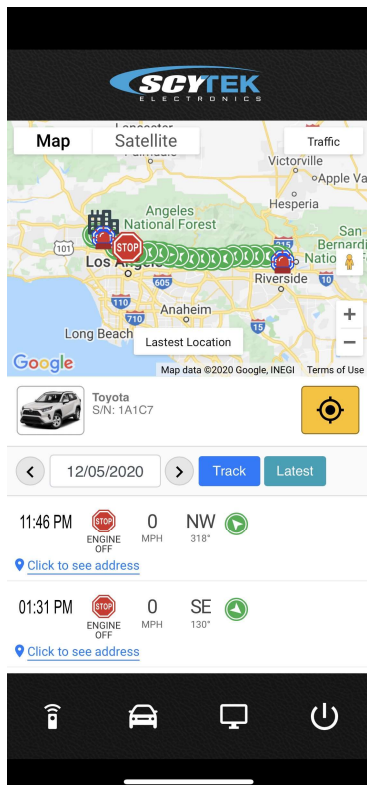

## About Your System

**G5, A4** Series is a **Combination Vehicle Security and Remote Starting System**, **G2, A1** Series is a Remote Starting with keyless entry. With proper installation this system will provide superior protection and performance for many years to come.

The Galaxy's G5/G2 Series built-in remote starter is designed to offer maximum convenience by remote starting your vehicle's engine, turning on the heater/air conditioner, and then running for a pre-determined time to provide a comfortable environment once you enter your vehicle.

To ensure the safety and security of the system while it is remote started, the G5/G2 Series employs several safeguards. In the event the alarm is triggered while the engine is remotely running, the remote start will immediately shutdown to prevent unauthorized users from attempting to drive the vehicle. The system is equipped with a hood pin input to prevent access to the engine compartment while the vehicle is remotely running. The Valet Mode prevents the remote start feature from operating in the event the vehicle is to be serviced. Finally, the brake pedal also acts as a safety by shutting down the remote start when pressed.

### System Contents:

- Main Unit
- One 5-Button 2-Way LCD Remote and One 1-Way 5-Button Remote Transmitter
- Two 5-Button Remote Transmitters (*RS & SP models*)
- High Output 6-tone Siren with G5, A4
- Dual Stage Shock Sensor with G5, A4
- Status LED/ Coded Emergency Override/ Valet Switch/ Call button built into the antenna (See Page 32)

### Options and Convenience Features\*\*

This ScyTek system includes several optional inputs and outputs allowing the creation of a completely personalized security and convenience system by offering many optional features such as:

**MobiLink** - Track and operate your system using Smart Phone.

**\*\*May require additional parts and/or labor, see store for details.**

- Second Car Operation
- Keyless Entry
- Two Stage Door Unlocking
- Starter Defeat
- Horn Honk
- Illuminated Entry
- Turbo Timer
- Remote Window Control
- Power Trunk / Hatch Release
- Glass Breakage Sensor
- Radar Sensor
- Remote Head Lamp Control
- Back-up Battery Siren

**Some of the features described in this manual may require additional parts and/or labor, and may not be included as part of the standard installation of this unit. Additionally, many features of these systems have selectable options that must be activated or programmed during the system's installation. These items will be identified in the following sections. Please discuss these features and any questions you may have regarding the installation of this product with Your Authorized Dealer.**

# Remote Transmitters

## ***Standard Remote Transmitter Description***



*Button 1* Arms and Locks the system and when held for 5 seconds, activates the system's Panic feature. Button 1 also locks the doors when the system is in Valet Mode.

*Button 2* Disarms and Unlocks the system. Pressing Button 2 again operates the Passenger Unlock feature (if installed). *Button 2* also unlocks the doors when the system is in Valet Mode.

*Button 3* Activates the Auxiliary 1 output. This output will remain on for as long as the button is pressed.

*Button 4* Activates the Remote Start feature.

*Button 5* is the Page Shift button. Each time the Shift Button is pressed, the LED on the transmitter will illuminate and the transmitter functions will shift to the next page, allowing access to another set of features. Once shifted to another page (there are 4 pages total), the transmitter will remain on that page for 10 seconds or until a button is pressed, then it will return to page 1. Under normal operation, only pages 1 and 2 are used. Pages 3 and 4 are usually used for Two Car Operation (see page 3).

*Shift then Button 1* Arms/Locks the system silently.

*Shift then Button 2* Disarms/Unlocks the system silently.

*Shift then Button 3* Activates the Auxiliary 2 output. This output will remain on for as long as the button is pressed.

*Shift then Button 4* Activates the Auxiliary 3/Factory rearm output.

# One Button Remote Transmitter



## A1.1 Series Remote

Program transmitter(s):

1. Turn on the ignition key On, Off, 4 times and then back On on fifth time.
  - The siren will chirp 5 times.
2. Press and hold the Override switch for 5 seconds.
  - The siren will chirp 5 times.
  - The LED will illuminate.
3. Press Button on the first transmitter.
  - The siren will chirp once.
4. Repeat step 3 for each transmitter (up to 4).
5. Turn off the ignition key.

**Note:** programming single button transmitter will set the system into a single button mode operation mode

### ***Remote Transmitter Operation Description***

**Lock:** press and release the button momentarily once - doors will lock within 2 seconds.

**Unlock:** press and release the button twice within 2 seconds - doors will unlock on the second button press.

**Remote Start/Stop:** press and hold the button for 3 seconds the system will remote start/stop.

### ***System Programming***

To enter System Programming:

1. Turn on ignition.
2. Within 5 seconds, press the valet switch 5 times.
  - The siren will provide three chirps, indicating that you have entered Programming.
3. Press the valet switch the number times equal to the System Option you want to change.
  - The siren will chirp each time the valet switch is pressed.
4. Within 5 seconds, press the transmitter button once
  - This siren will chirp

Press the valet switch the number times equal to the desired operating system option.

- The siren will chirp to indicate the corresponding setting.

1 chirp	=	Column 1
2 chirps	=	Column 2
3 chirps	=	Column 3

5. When finished, turn off the ignition to save the changes.

## ***Adding/Replacing Standard Remote Transmitters***

To replace lost or stolen transmitters or to add additional transmitters into the system, have all desired transmitters ready and follow the steps below.

**Note:** Up to 4 one-way transmitters can be programmed to operate the system. Any previously stored transmitter will be erased if it is not programmed within the following sequence

To program the transmitter(s):

1. Turn the ignition key On, Off, On, Off, and back On ( Key On 3 times, leave key in the on position) .
  - 3 seconds later The siren/horn will chirp/honk 3 times.
2. Press and hold the Override switch for 5 seconds.
  - The siren/horn will chirp/honk 5 times.
  - The LED will illuminate.
3. Press Button 1 on the first transmitter.
  - The siren/horn will chirp/honk once.
4. Repeat step 3 for each transmitter (up to 4).
5. Turn off the ignition key.

## ***Two Car Operation***

If two vehicles are equipped with the G5/G2 Series systems, for convenience both can be operated using the same remote transmitter. If all four transmitters are to be used with both cars, program transmitters A and B into the first vehicle in the manner described above. Program transmitters C and D by pressing the Shift button twice before performing steps 3 and 4 above.

When finished programming the first vehicle, program transmitters C and D into the second vehicle as normal, then program transmitters A and B by pressing the Shift button twice before performing step 3.

When programmed in this manner, the driver of the first car can also operate the second vehicle by pressing the Shift button twice and the desired function button.

## ***Battery Replacement***

The **T5** Remote Transmitter uses one 3 volt lithium batteries (type CR2032)

Depending on the amount of use, the batteries may last up to 4 years or more before they need replacement.

In order to change the battery, first remove the screw from the back of the transmitter and separate the top and bottom halves of the case. While replacing the battery make sure that the positive and negative terminals are positioned correctly, then carefully reassemble the transmitter case.



## 2-way LCD Remote Transmitter Description



### Page 1

*Button 1* Arms and Locks the system and when held for 3 seconds, activates the system's Panic feature. Button 1 also locks the doors when the system is in Valet Mode.

*Button 2* Disarms and Unlocks the system. Pressing Button 2 again operates the Passenger Unlock feature (if installed). Button 2 also unlocks the doors when the system is in Valet Mode.

*Button 3* Activates the Auxiliary 1 output normally used for trunk release (note trunk icon on button).

*Button 4* Activates the Remote Start feature.

*Button 5* is the Confirmation, Programming and the Page Shift button. Quickly pressing button 5 will activate the Page 2 function. Pressing button 5 for 2 seconds activates the system's confirmation feature which will then display the current status of the system (armed, disarmed, engine running, etc.).

### Page 2

*Button 1* Silently Arms/Locks the system.

*Button 2* Silently Disarms/Unlocks the system.

*Button 3* Activates the Auxiliary 2 output.

*Button 4* Aux 3 or Factory Rearm output.

*Button 5* Not Implemented. **Page 3 & 4** are used as **Page 1 & 2** for second car operation

## LCD Transmitter Battery Replacement

Your Pager Remote Transmitter **T5-2W** uses a 1.5 volt AAA alkaline battery, which will require replacement in time. Depending on the amount of use, the battery may last up to 3 months before it needs replacement. When the battery needs replacing, the system's operating range will decrease, the LCD display will show only one of three bars in the battery icon, or the display and sounds may suddenly stop and start as the battery voltage drops below minimum.

In order to change the battery, first slide the battery door locking pin to the side. Carefully slide the battery cover downward until it is free. While replacing the battery make sure that the positive and negative terminals are positioned correctly, then carefully reassemble the transmitter case.

## ***Adding/Replacing 2-way LCD Transmitters (2 LCD remotes maximum)***

When adding an optional 2-way LCD transmitter to the system, follow these steps:

1. Turn on the ignition key On, Off, On, Off, On, Off, and back On. (Key On 4 times, leave key in the on position).
  - 3 seconds later the siren will chirp 4 times.
2. Press and hold the Override switch for 5 seconds.
  - The siren will chirp 4 times.
  - The LED will illuminate.
3. Press Button 1 on the first transmitter, then on the second transmitter.
  - The siren will chirp once for each transmitter learned.
4. Turn off the ignition key.
5. The siren will chirp 3 times to indicate the system has exited programming mode.

## ***Setting The Time***

The LCD display is equipped with a 12-hour clock

Set the time:

1. Press and hold Buttons 2 (unlock) and 4 (start) for two seconds.
  - The remote will beep two times and c1 will be shown indicating time set mode is entered, release the buttons.
2. Press and release Button 2 (unlock) until the correct hour is displayed. (hold button to scroll).
3. Press and release Button 4 (start) until the desired minute is displayed. (hold button to scroll).
4. When the desired time is displayed, press Button (function) 5 to store.
  - The remote will beep 3 times to indicate the time has been set.

## ***Power Save Mode***

Power save mode disables automatic pager operations, alarm and starter status must be checked manually using button 5 for confirmation.

1. Press and hold Buttons 2 and 3 until the remote beeps six times.
  - "SLP" is shown indicating Power Save set/reset mode is entered.
2. Press Button 1 to toggle Power Save On/Off.
  - The remote will display On or Off indicating the current status of the pager.

Pager power save mode status EXT (battery life extended) is indicated above the battery icon

## ***Automatic Cold Start Temperature Setting (2 step procedure, for second step see page 7 under "Cst")***

The Automatic Cold Start setting sets the temperature threshold. If automatic start is set to cold temperature setting, the starter will activate every 2 or 4 hours if the temperature drops below the set value. (LED will flash slow in this mode)

1. Press and hold Buttons 2 and 3 until the remote beeps five times.
  - "cold" is shown indicating automatic cold start temperature set mode is entered.
2. Press Button 2 to increase the temperature.
3. Press Button 4 to decrease the temperature.
4. When the desired temperature is displayed, press Button 1 to store the value.
  - The remote will display the temperature and beep 3 times then 4 times to indicate the set temperature.

### ***Automatic Hot Start Temperature Setting (2 step procedure, for second step see page 7 under "H st')***

The Automatic Hot Start setting sets the temperature threshold. If automatic start is set to hot temperature setting, the starter will activate every 2 or 4 hours if the temperature rises above the set value. ( LED will flash slow in this mode)

1. Press and hold Buttons 2 and 3 until the remote beeps six times.
  - "hot" is shown indicating automatic hot start temperature set mode is entered.
2. Press Button 2 to increase the temperature.
3. Press Button 3 to decrease the temperature.
4. When the desired temperature is displayed, press Button 1 to store the value.
  - The remote will display the set temperature and beep 3 times then 4 times to indicate the set temperature.

### ***LCD Backlight***

Transmitter Button 5 is used for confirmation, transmitter programming, as well as activation of the LCD backlighting for use in the dark. Press and release button 5 momentarily to activate the LCD backlight.

### ***System Confirmation***

The 2-way transmitter's confirmation feature allows the current vehicle status to be displayed at any time.

To display system status:

1. Press and hold Button 5 until the display shows CON.
  - The transmitter will beep once.
2. Release Button 5.
  - The transmitter will beep once.
  - The LCD panel will display the current system status.

### ***Programmable Functions using the LCD Transmitter***

Pressing and holding transmitter button 5 will scroll through several transmitter programmable options - **C St, H St, Snd** .

**F** Check the temperature inside the vehicle

1. Press and hold Button 5 until the display shows F
  - The transmitter will beep twice.
2. Release Button 5.
  - The transmitter will beep four times.
  - The LCD panel will display the temperature inside the vehicle

**C St** Auto Start Cold Temperature Activation Mode.

1. Press and hold Button 5 until the display shows **C St**.
  - The transmitter will beep 6 times.
2. Release Button 5.
  - The transmitter will beep once.
  - The LCD panel will show Auto Start Cold Temperature setting.
3. Press and hold Button 5 until the display shows **CON**.
4. Release Button 5.
  - The transmitter will beep once.
  - The LCD panel will show "**ON**" indicating that Auto Start Cold Temperature Activation Mode is enabled.

**H St** Auto Start Hot Temperature Activation Mode.

1. Press and hold Button 5 until the display shows **H St**.
  - The transmitter will beep 7 times.
2. Release Button 5.
  - The transmitter will beep once.
  - The LCD panel will show Auto Start Hot Temperature setting.
3. Press and hold Button 5 until the display shows **CON**.
4. Release Button 5.
  - The transmitter will beep once.
  - The LCD panel will show "**ON**" indicating that Auto Start Hot Temperature Activation Mode is enabled

**ASND** sound function selects the transmitter's confirmation mode - Tone or Vibration mode.

Set the transmitter confirmation tones ON or OFF:

1. Press and hold Button 5 until the display shows **SND**.
  - The transmitter will beep 9 times.
2. Release Button 5.
  - The transmitter will beep once.
  - The LCD transmitter will beep 5 times and display "on" if the sounds are enabled or vibrate and display "off" for the Remote to vibrate.3

sound function selects the transmitter's confirmation mode - Tone or Vibration mode.

In the event the alarm is triggered and remains triggered continuously by the same sensor or input during a single arming cycle, that sensor or input will be automatically bypassed until the next time the system is armed.

If the Shock Sensor detects a light impact to the vehicle the siren will chirp 5 times as a warning indication.

# System Operation

## **Remote Arming/Locking**

The system monitors 5 independent areas (**zones**) while armed: doors, hood/ trunk, shock sensor, optional sensor input.

To Arm and Lock the System:

1. Turn off the ignition.
  2. Press Button 1.
    - The siren/horn will chirp/honk once.
    - The doors will lock.
    - The parking lights will flash once.
    - The LED will turn ON, to indicate the starter defeat is activated.
  3. 10 seconds after Arming/ Locking:
    - The LED will start blinking to indicate that the doors, hood, trunk and sensor inputs are being monitored.
- \* **During Arming, if the system detects a bad sensor or an open zone, the system will chirp 4 additional times and ignore that input, but keep all other areas protected.**

Once Armed, the alarm will trigger when any of the following occurs:

- **The doors are opened.**
- **The hood or trunk is opened.**
- **The shock sensor detects an impact to the vehicle.**
- **An optional sensor is disturbed.**

When the alarm triggers, the siren will sound, the horn will honk, and the parking lights will flash. If the system is triggered by the doors, hood, or trunk, the system will alarm for 45 seconds. If triggered by the sensor inputs, the system will alarm for 30 seconds.

In the event the alarm is triggered and remains triggered continuously by the same sensor or input during a single arming cycle, that sensor or input will be automatically bypassed until the next time the system is armed.

If the Shock Sensor detects a light impact to the vehicle the siren will chirp 5 times as a warning indication.

## **Remote Disarming/Unlocking**

To Disarm and Unlock the System:

Press Button 2.

- The siren/horn will chirp/honk twice.
- The doors will unlock.
- The parking lights will flash twice.
- The dome light will turn on.\*\*
- The LED will turn off.

\* **During Disarming, if the system was triggered while away from the vehicle, the siren will chirp 3 times and the LED will flash to indicate triggered zone. See *Tamper Alert* for zone listing.**

\*\* **If the Optional Dome Light Activation feature is installed.**

## ***Tamper Alert***

If the system was triggered while away, the LED will flash to indicate which zone triggered the system after disarming and turning the ignition ON. The LED indication will repeat 8 times.

LED Flashes (60 seconds):

<b>1 flash</b>	<b>=</b>	<b>optional sensor</b>
<b>2 flashes</b>	<b>=</b>	<b>shock sensor</b>
<b>3 flashes</b>	<b>=</b>	<b>network based sensor</b>
<b>4 flashes</b>	<b>=</b>	<b>door</b>
<b>6 flashes</b>	<b>=</b>	<b>hood/trunk</b>

**example: flash-flash-pause-flash-flash-pause = shock sensor**

## ***Silent Arming/Disarming***

The G5/G2 Series system can be programmed to operate the system without Arm/Lock and Disarm/Unlock chirp/honk confirmations. When programmed for full-time silent operation, the siren will sound only when the system is triggered.

The system is also capable of temporary silent operation if desired. Pressing the Shift button before Arming/Locking or Disarming/Unlocking, the system will bypass the chirp/honk confirmations and allow one-time silent operation.

**Note: The open zone warning chirps will not be bypassed when the system is Armed or Disarmed silently.\***

## ***Passive Arming***

When programmed for the optional Passive Arming feature, the system arms itself automatically, each time the ignition is turned off and all of the doors, hood, and trunk are closed.

To start the Passive Arming Process:

1. Turn off the ignition.
2. Open the door and exit the vehicle.
  - Once all doors are closed and the dome light is off, the LED will begin flashing rapidly.
  - The parking lights will flash twice indicating the Passive Arming sequence has begun.
3. After 30 seconds,
  - The siren will chirp.
  - The parking lights will flash.
  - The doors will lock.\*\*\*
  - The status LED will begin flashing slowly.
4. The system is now armed.

**\*\* \* If the Passive Locking feature is selected.**

## ***Panic Mode***

In the event of an emergency, the transmitter's remote Panic feature can be used to instantly trigger the alarm/panic feature.

To activate the Panic Mode:

1. Press and hold Button 1 for three seconds.
  - The alarm will sound.
  - The parking lights and horn will flash.
  - The doors will unlock\*\* allowing access to the vehicle.
2. Press Button 1 or 2 to stop Panic Mode.

**\*\*If the ignition is on when the Panic feature is activated, the doors will lock for personal safety.**

If not deactivated using Buttons 1 or 2, the Panic Mode will automatically exit after 40 seconds.

## ***\* Emergency Override***

If the transmitter becomes lost or inoperable, the system can still be disarmed using the following procedure. Before beginning this procedure be sure to have the ignition key ready and know the location of the override switch.

To Emergency Override the system:

1. Unlock the door using the key.
2. Enter the vehicle.
  - The system will trigger and the siren will sound.
3. Turn the ignition key to the ON position.
4. Press and hold the override switch until the alarm turns off (approximately 5 sec.)
  - The system will disarm.
5. The vehicle will now be able to start.

## ***Optional Coded Emergency Override***

As an extra measure of security, the G5/G2 Series is equipped with an optional Coded Emergency Override feature. Once an Emergency Override Code is chosen and programmed during installation, the system can no longer be disarmed using the standard override procedure.

To Emergency Override the system using the Code:

1. Follow steps 1-3 above.
2. Press the override switch a number of times equal to the Disarm code of you have chosen, and continue holding for 10 seconds on the last press.
  - The system will disarm. If the code is entered incorrectly, turn off the ignition and begin again.

To set the Emergency Override Code:

1. Turn the ignition switch to the ON position.
2. Within 5 seconds, press the valet switch 5 times.

- The siren will provide one long chirp indicating that you have entered Programming.
- 3. Press the valet switch 4 times.
  - The siren will chirp each time the valet switch is pressed.
- 4. Within 5 seconds, press Button 3 on the transmitter.
  - The siren will chirp 3 times.
- 5. Press the valet switch the number of times equal to the desired code (from 1-15).
- 6. Turn off the ignition then arm the system.
- 7. Disarm the system using the new Override Code to permanently store the new code.

**Note:** If the code set procedure is not properly performed, turn off the ignition and begin again. The override code will not be permanently stored until the code is used to disarm the system.

## ***Automatic Rearming***

The Automatic Rearming feature is designed to protect the vehicle in the event the system is accidentally disarmed. With the Automatic Rearming feature enabled, the alarm will automatically rearm and lock doors 30 seconds after disarming. Automatic Rearming feature will be temporarily bypassed until the next arming cycle if the ignition is turned on.

## ***Valet Mode***

The Valet Mode temporarily disables the Security and/or Remote Start System so that the vehicle may be operated by a mechanic or parking attendant.

To activate the Valet Mode:

1. Turn the ignition switch to the ON position.
2. Press and hold the override switch for 5 seconds.
  - The siren/horn will chirp/honk once and the LED light will stay ON to confirm the Valet Mode is on.
3. Repeat steps 1 and 2 to deactivate the Valet Mode.
  - The siren/horn will chirp/honk twice and the LED light will turn off to confirm the Valet Mode is off.
4. Turn off the ignition.

While in Valet Mode the remote transmitters will continue to lock and unlock the doors, and operate the optional auxiliary functions.

## ***DRIVER CALLING/PAGE FEATURE***

The G5/G2 Series is equipped with a driver calling or paging feature that allows the system to send a page to the LCD transmitter in the event the transmitter has been misplaced or lost (must be within 1500 feet)

To activate the DRIVER CALLING/PAGE feature:

1. Locate the Valet/Emergency Override button in your vehicle.
  - With the ignition switch OFF, press and hold the Valet/Emergency override button for 2 seconds, then release.
  - The LCD transmitter will beep continually and the "DRIVER CALLING" icon will appear.
  - Press and release button 5 to turn off transmitter page.



# Remote Start Features

## **Remote Starting**

To Remote Start the System:

1. Be sure the system is not in Valet Mode.
2. Press and hold Button 4 for three seconds.
  - The parking lights will flash 4 times and turn on.
  - The siren/horn will chirp/honk 4 times. ( if enabled, see page 24 branch 9 )
  - The engine will start and run for the duration of its programmed Run Time.\*\*
  - The heater or air conditioner will turn on (if turned on prior to exiting the vehicle).

**\*\*If the engine fails to start on the first attempt, it will repeat the starting procedure 2 more times. If the vehicle fails to start after a total of 3 times the parking lights will flash 4 times and the doors will lock (if installed).**

Turn on the ignition and press the brake pedal to disengage the remote start feature and drive the vehicle.

## **Shut Down**

When the the Remote Start feature is active, any of the following actions will shut down the engine:

1. Pressing Button 4.
  - After the engine shuts down the doors will lock **(if the optional keyless entry feature is installed)**.
2. Pressing the Brake Pedal.
3. Opening the Hood.
4. Remote Start Time-Out (completion of the timed run cycle).

## **Quick Stop**

The Quick Stop Feature allows you to exit the vehicle while keeping the engine running for quick stops.

To leave the vehicle running:

2. While the engine is running push the Remote Start button on the Remote Transmitter.
  - The parking lights will flash twice and will stay on.
4. Remove the key from the ignition switch.
5. You may now exit the vehicle and lock the doors manually or by using the Remote Transmitter

To resume control of the vehicle:

1. Unlock the doors manually or by pressing the Disarm/Unlock Button on the Remote Transmitter.
2. Turn on the ignition.
3. Press the Brake Pedal to disengage the remote start.
  - The parking lights will turn Off.

## ***Automatic Start Mode***

**Automatic Start feature has three modes that will start the vehicle every one or two hours within a 24 hour period.**

1. **Timer Only Mode (factory default)**

The Automatic Start feature starts the vehicle automatically every one or two hours and runs for the preset Run Time. (15 or 25 min)

Auto Start on Timer Mode:

1. Turn Ignition switch Off and wait for 3 seconds.
2. Turn Ignition switch On and Off three times ending with Ignition in Off position
3. Press the Valet switch immediately after.  
parking lights will flash indicating that the Auto Start mode has been activated.

2. **Low Temperature Start Mode\*\***

The Automatic Start feature starts the vehicle automatically for a preset Run Time every one or two hours if the temperature in the vehicle drops below the preset value (factory default -15°F).

3. **High Temperature Start Mode\*\***

The Automatic Start feature starts the vehicle automatically for a preset Run Time every one or two hours if the temperature in the vehicle exceeds the preset value (factory default 138°F).

**\*\* See the 2-way LCD Remote Transmitter section for Auto Start Cold or Hot Temperature Activation.**

### **To disable Auto Start function**

Do one of the following:

- Turn ignition On.
- Arm/Lock and then Disarm/Unlock the system.
- Alarm or Panic the system.

## ***Turbo Timer Feature***

The optional Turbo Timer feature allows vehicles with turbocharged engines to remain running after the ignition key is removed, for proper cool-down of the turbocharger. The Turbo Timer feature requires connection to the vehicle's parking brake wire. (turbo timer feature must be enabled).

To activate the Turbo Timer feature:

1. Leave the engine running after parking the vehicle.
2. Set the vehicle's parking brake.
  - The Turbo Timer will begin a two-minute run cycle to allow the turbocharger to cool down.
3. Turn OFF the ignition and exit the vehicle.

To deactivate the Turbo Timer feature:

1. Release the emergency/parking brake.
2. Re-apply the vehicle's parking brake.
  - The Turbo Timer 2 minutes countdown will automatically stop and the engine will shutdown.

**WARNING:** the Turbo Timer feature is not intended for use inside garages or other non-ventilated areas. Make sure to deactivate the Turbo Timer feature when parking in such areas.

# Manual Transmission Remote Start Features

## Model: G5-M/G2-M

- 1- Tach wire must be connected , The system must learn RPM.
- 2- Hand brake wire must be connected.
- 3- Door trigger wire must be connected
- 4- Clutch override installed **NOTE: MUST USE RELAY, SEE PAGE 28.**

## **Remote Starting ready**

With engine running and Hand-brake engaged put the vehicle transmission in neutral and remove the foot from the brake pedal, press the remote start button on your transmitter, parking lights will flash twice indicating Manual Start Mode is enabled, turn off the Ignition switch, the engine will remain running. Open and close the door, the system will shut the engine Off. Using the remote Control, Arm/Lock the vehicle. Vehicle is now ready for remote start operation.

**Starter Ready Mode is canceled any time the door is opened; hand brake is released or any other error condition.**

To Remote Start the System:

1. Be sure the system is not in Valet Mode.
2. Press and hold Button 4 for three seconds.
  - The parking lights will flash 4 times than will stays on.
  - The LED will flash rapidly.
  - The engine will start and run for the duration of its programmed Run Time.\*\*
  - The heater or air conditioner will turn on (if turned on prior to exiting the vehicle).

**\*\*If the engine fails to start on the first attempt, it will repeat the starting procedure 2 more times. If the vehicle fails to start after a total of 3 times the parking lights will flash 4 times and the doors will lock (if installed).**

Turn on the ignition and press the brake pedal to disengage the remote start feature and drive the vehicle.

## **Shut Down**

When the the Remote Start feature is active, any of the following actions will shutdown the engine:

1. Pressing Button 4.
  - After the engine shuts down the doors will lock (if installed).
2. Pressing the Brake Pedal.
3. Opening the Hood. (*safety switch must be installed*)
4. Remote Start Time-Out (completion of the timed run cycle).
5. Emergency Brake Off.

## Extended Features

### ***Ignition Door Locking***

For added safety, the Ignition Door Locking feature allows vehicles equipped with power door lock systems to automatically lock the doors when the ignition is turned on. If a door is open when the ignition is turned on, the Ignition Door Locking feature is disabled to protect against locking the keys inside the vehicle. If RPM is selected Doors will lock when engine RPM exceed 2.5 times the idle.(tach wire must be connected)

### ***Ignition Door Unlocking***

For added convenience, this feature automatically unlocks the doors after the ignition key is turned off. If the optional Passenger Unlock feature is installed, the Ignition Door Unlocking feature can be programmed to unlock only the driver door as a higher measure of safety, especially when children are present. The Ignition Door Unlocking feature may also be completely disabled if desired.

### ***Dome Light Activation***

If the optional Dome Light Activation feature is installed, the dome light will turn on when the system is disarmed using the Remote Transmitter, and remain on for 30 seconds or until the ignition is turned On.

### ***Auxiliary Function Outputs***

The Galaxy G5/G2 Series system is equipped with 3 Auxiliary Channel Outputs allowing the convenience features of the system to be further expanded. Aux-2 output can be programmed for pulsed, timed, or latched operation and used to add a number of optional features such as: power trunk release, power window activation, power sunroof control, auxiliary lighting, audio/video system control, and more.

The **Pulsed** operation setting allows an output to activate as long as the button is held.(1-way remote only)

The **Timed** operation setting allows an output to activate when the transmitter button is pressed, and remain activated for 10 seconds or until the transmitter button is pressed again.

The **Latched** operation setting allows an output to activate when the transmitter button is pressed, and remain activated until the transmitter button is pressed again.

### ***Disarm with Auxiliary Function***

If the Auxiliary 1 option is installed to activate the vehicle's trunk release, the system can be programmed to automatically disarm the alarm when the trunk is opened using the transmitter. In this manner, the trunk can be accessed without first disarming the alarm.

### ***Remote Sensor Disable***

When parking the vehicle in areas susceptible to unwanted disturbance from animals or strong weather conditions that could cause the sensors to trigger, the sensor inputs can be temporarily bypassed using the Remote Transmitter, preventing possible false alarms.

To disable the sensor inputs :

1. Arm the system normally.
2. Within 5 seconds of Arming the system, press the Arm button again.
  - The siren will chirp 5 times and the parking lights will flash 5 times to indicate the sensors are disabled.
  - The sensors will remain disabled until the next arming cycle.

## System Installation

1. Thoroughly read and become familiar with the installation instructions before beginning the installation.
2. Review system contents:
  - Main Unit
  - 1 or 2 One-way 5 Button Remote Transmitters (varies by model)
  - 1 or 2 Two-way 5 Button LCD Remote Transmitters (varies by model)
  - Siren
  - Shock Sensor
  - Harnesses
    - 6-Pin starter harness
    - 20-Pin main harness
    - 4-Pin shock sensor harness
    - 3-Pin door lock harness
    - LED harness
    - Override Switch harness
    - 5 Pin antenna harness
3. Verify vehicle is equipped with electronic fuel injection, and starts/idles normally before installation.
4. Determine if vehicle is equipped with a factory theft deterrent system and obtain proper bypass module if required.
5. Find a location to mount the hood pin switch that will not interfere with the opening of the hood, and is not in a position that can accumulate water. **The hood pin is a safety device that must be installed to avoid remote starting during engine servicing.**
6. Verify with the owner, the mounting locations for all visible components, including the LED and Override switch.
7. Verify with the owner, the optional features of the Galaxy G5/G2 Series and the features that must be programmed during installation.
8. Inspect and perform a function test of all vehicle systems before and after the installation.
9. Always use a Volt / Ohm meter for testing vehicle circuits. Never use a test light.
10. Always look before drilling any holes or mounting self-tapping screws. Be sure fuel lines and exterior wiring looms are clear as they are often close to the chassis and difficult to see.
11. Protect all wires running from the engine compartment to the interior of the vehicle by covering with electrical tape and split loom tubing. Be sure to use a grommet when routing wires through the firewall.
12. Properly fuse any additional accessories such as window modules, door lock actuators, etc., making sure to power them separate from the alarm module. This will ensure the functionality of the security system in the event of an accessory failure.

## ***Mounting the Control Unit***

The control unit must only be mounted in the interior of the vehicle. Do not mount the main unit in the engine compartment. Choose a mounting location that will not be easily accessible to a thief, and will not interfere with the operation of any vehicle components such as foot pedals, steering column, air vents, seat rails, etc.

Do not mount the control unit until after setting the internal jumpers and performing a complete operation check of the system. After installation is complete and performance verified, the control unit can be easily mounted using wire ties through the mounting tabs on the bottom of the unit.

## ***Mounting the Siren***

Choose a siren mounting location that is away from heat sources such as exhaust manifolds, and where it cannot be easily accessed from underneath the vehicle. Be sure to face the siren downward to prevent the collection of water in the siren's housing.

Always route all wires from the engine compartment into the interior of the vehicle through a proper grommet.

## ***Mounting the Shock Sensor***

Choose a suitable interior mounting location for the shock sensor that provides ample coverage of the vehicle. Suggested mounting locations include air conditioning ducts, dashboard braces, or center console supports.

During proper operation, the shock sensor will detect impacts to the vehicle only and will not usually be triggered by slow rocking movements of the vehicle like those caused by wind.

# System Wiring

## **6-Pin Starter Harness**

- Pin 1 **RED WIRE A:** Main Power Input A (+). Connect to the battery or constant power wire at the ignition switch with a minimum 25 Amp supply. Remove the fuse until the installation is complete and all wiring is checked.
- Pin 2 **RED WIRE B:** Main Power Input B (+). Connect to the battery or constant power wire at the ignition switch with a minimum 25A supply. Note: if connecting at the ignition switch it is highly recommended to use separate power wires for each Red wire, each with a minimum 25A supply. Remove the fuse until the installation is completed and all wiring is checked.
- Pin 3 **BROWN WIRE:** Second Ignition Output (+). The Brown wire provides +12V for a second ignition wire. This wire may instead be programmed for use as a second accessory or second starter wire.
- Pin 4 **ORANGE WIRE:** Accessory Output (+). Connect to the accessory wire coming from the ignition switch that supplies power to the heater/air-conditioner. Some cars may have multiple accessory wires.
- Pin 5 **YELLOW WIRE:** Ignition Output (+) And Input . Connect to the main ignition wire that provides +12V when the ignition is on and while cranking the starter. This wire also acts as an ignition input.
- Pin 6 **VIOLET WIRE:** Starter Output (+). Connect to the the vehicle's starter wire.

## **20-Pin Main Harness**

- Pin 1 **GREEN/WHITE WIRE:** Brake Input (+). Connect to the wire that shows +12V when pressing the brake. The Green/white wire is a safety shutdown wire that **must be connected.**
- Pin 2 **BLACK/GRAY WIRE:** Tach Input. Connect to the vehicle's tach wire or a fuel injector wire if the tachless mode does not provide satisfactory operation.
- Pin 3 **WHITE/RED WIRE:** Auxiliary 2 Output (-) 500 mA. Connect to a relay or module for an optional feature such as power window activation, etc. This output may be programmed for momentary, timed, or latched operation.
- Pin 4 **BLACK/WHITE WIRE:** Dome Light Output (-) 500 mA. Connect to the wire that activates the vehicle's dome light, usually the door pin switch wire (see Green and Violet door trigger wires). **Note: MUST USE RELAY(see page 26)**
- Pin 5 **YELLOW WIRE:** Emergency brake Input (-). G5M/G2M/A4M/A1M Series, use only for vehicles equipped with manual transmission, connect to the wire that shows (-) when emergency brake is engaged.
- Pin 6 **BLUE/YELLOW WIRE:** Glow Plug Input (+). For vehicles equipped with diesel engines the Blue/yellow wire must be connected to the wait-to-start light in the gauge panel. This wire will show +12V when the light is on, and ground when the light turns off. If the wait-to-start wire shows ground when the light is on, a relay must be installed (see wiring diagrams).
- Pin 7 **BLUE/WHITE WIRE:** Passenger Unlock Output (-) 500 mA. Connect to a relay to unlock the passenger doors when the system is configured for Driver Priority Unlocking.
- Pin 8 **BLUE/ORANGE WIRE:** Ground When Running Output (-) 500 mA. Connect to an optional factory security bypass module if required **Or to a clutch switch bypass relay pin#86 for manual transmissions**
- Pin 9 **BLACK WIRE:** Module Ground Input (-). The Black wire must connect to a solid chassis ground. Clean away any paint or dirt to insure the best possible ground.
- Pin 10 **RED WIRE:** Module Power Input (+). Connect to a constant source of +12V.

- Pin 11 **VIOLET WIRE:** Positive Door Input (+). Connect to the door switch circuit wire that shows +12V when the door is open. This type of door circuit is usually found on Ford vehicles.
- Pin 12 **GREEN WIRE:** Negative Door Input (-). Connect to the door switch circuit wire that shows ground when the door is open.
- Pin 13 **WHITE/BLACK WIRE:** Hood/Trunk Pin Input (-). Connect the to the hood/trunk pin switch. The switch must provide a ground output when switch is opened.
- Pin 14 **ORANGE WIRE:** Armed Output (-) 500 mA. The Orange wire provides a ground output while armed to activate a relay for starter defeat and anti-grind protection or window rollup module.
- Pin 15 **VIOLET/WHITE WIRE:** Factory Disarm Output (-) 500 mA. The Violet/white wire provides a ground output on disarming and before remote starting to disarm a factory security system. Connect to the wire that requires a ground pulse to disarm the factory security system.
- Pin 16 **WHITE/VIOLET WIRE:** Auxiliary 3 / Factory Rearm Output / Ignition 3,(-) 500 mA. Programmable Factory Rearm Output: provides a ground output on remote start shutdown to rearm a factory security system. Connect to the wire that requires a ground pulse to rearm the factory security system.
- Pin 17 **BROWN WIRE:** Siren Output (+) 3A. The Brown wire must connect to the siren's red wire. The Black siren wire must be grounded.
- Pin 18 **GRAY WIRE:** Auxiliary 1 Output (-) 500 mA. Connect to a relay for an optional feature such as trunk release, etc. *This output may be programmed for momentary, timed, or latched operation.\**
- Pin 19 **WHITE WIRE:** Parking Light Output (+/-) relay. Connect the White wire to the circuit that shows +12V or ground only when the parking lights are on and set the internal parking light relay jumper to the proper polarity. For parking light circuits exceeding 10 amps, a relay is required. For vehicle's with independent left and right parking light circuits, diodes must be installed to keep the circuits separate. NOTE: Do not connect the WHITE wire directly to the vehicle's headlight circuit.
- Pin 20 **BROWN/WHITE WIRE:** Horn Output (-) 500 mA. Connect to a relay to activate the vehicle's horn when the alarm is triggered.

## ***Plug-in Connectors***

- 4-Pin White Connector:** Dual stage shock sensor port.( Can Also be used for optional Sensor, Radar, Glass, etc)
- WHITE WIRE: (-)Warn-Away Input For Optional Sensor. (G2, A1, Three (-) pulse starts and shuts off engine)
  - BLUE WIRE: (-)Trigger Input For Optional Sensor. (G2, A1, one (-) pulse starts and shuts off engine)
  - RED WIRE: (+) 12 volt Output For Optional Sensor.
  - BLACK WIRE: (-) Ground Output For Optional Sensor.
- 2-Pin Blue Connector:** Valet switch port. plug the blue connector from antenna harness into this port.
- 2-Pin Red Connector:** LED port. plug the red connector from antenna harness into this port.
- 3-Pin White Door Lock Connector:** Door lock port.
- BLUE WIRE - negative unlock output (-) 500mA.
  - GREEN WIRE - negative lock output (-) 500mA.



**4-Pin Black DBP Connector:** The plug-in DBP connector port is located on the side of the main module.  
this DBP port may be used with the optional bypass modules for data bus interface.

### ***Jumper Selection***

Carefully separate the top and bottom halves of the main unit case. Once the cover is removed, the parking light polarity jumper will be visible next to the parking light relay. Set the jumper for the correct polarity output as described below, then reassemble the main unit case.

**Parking Light Output.** Selects the polarity (+/-) for the output of the on-board Parking Light relay.

Left Pin + Center Pin = positive ( Default setting is ( + )

Right Pin + Center Pin = negative

## Jumper Settings

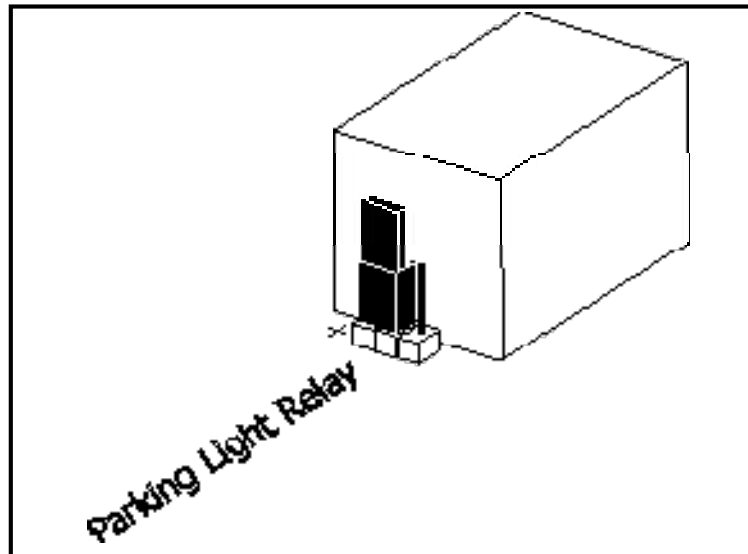

default setting shown

# System Programming

## ***Entering System Programming***

This system is compatible with both the LCD two way transmitter or the standard transmitter, all system programming can be performed using either one.

### **To enter System Programming using standard 5 button remote:**

1. Turn the ignition switch to the ON position.
2. Within 5 seconds, press the valet switch 5 times.
  - The siren/horn will provide three chirps/honks, indicating that you have entered Programming.
3. Press the valet switch the number times equal to the System Parameter you want to change.
  - The siren/horn will chirp/honk each time the valet switch is pressed.
4. Within 5 seconds, press the transmitter button corresponding to the desired operating mode for that System Parameter.
  - The siren/horn will chirp/honk to indicate the setting.

1 chirp/honk	=	Button 1
2 chirps/honks	=	Button 2
3 chirps/honks	=	Button 3
5. When you are finished, turn off the ignition to save the changes.

### **To enter System Programming using one button remote:**

1. Turn the ignition switch to the ON position.
2. Within 5 seconds, press the valet switch 5 times.
  - The siren/horn will provide three chirps/honks, indicating that you have entered Programming.
3. Press the valet switch the number times equal to the System Parameter you want to change.
  - The siren/horn will chirp/honk each time the valet switch is pressed.
4. Within 5 seconds, press the transmitter button once
  - This siren/horn will chirpPress the valet switch the number times equal to the desired operating system option.
  - The siren/horn will chirp/honk to indicate the setting.

1 chirp/honk	=	Column 1
2 chirps/honks	=	Column 2
3 chirps/honks	=	Column 3
5. When you are finished, turn off the ignition to save the changes.

## ***Default Reset***

Following this procedure will set all System Programming Parameters to factory default settings.

1. Enter System Programming.
2. Press Transmitter Button 3.
  - The siren/horn will chirp/honk 6 times indicating that the reset signal was received.
  - All System Programming parameters are now set to factory default settings.
  - The Valet Mode is off.
3. Turn off ignition.

## Programming Branch Table

Branch	Feature	Button 1 (default)	Button 2	Button 3	Button 4
1	Arm Mode	Manual Arming	Passive Arming		
2	Auto Rearming Mode	Disabled	Enabled		
3	Arming Chirps	Siren Chirps On	Siren & Horn Chirps On	Silent	Data Bus Module ADS
4	Ignition Door Locking	On	Off	Set Override Code	Data Module Fortin
5	Ignition Door Unlocking	Unlock All	Unlock Driver Only	Off	Fortin RF Kit Enable
6	Door Unlock Pulse	Single	Double		Remote Start History
7	Door Lock Pulse Length	1 second	3 seconds	0.1 seconds	
8	Passive Door Locking	Disabled	Enabled		
9	Start Confirmation Chirps	Disabled	Enabled		Enable Aux Start
10	Ignore Open Door Report	Off	Ignore		Temp mode oF
11	Aux 1 Mode	Pulsed	Timed	Latched	Temp mode oC
12	Aux 2 Mode	Pulsed	Timed	Latched	
13	Aux 3 Mode	Pulsed	Timed	Latched	
14	Disarm with Aux 1	Disabled	Enabled		
15	Aux 2 Activate on Arm	Off	On		
16	Aux 3 Output Mode	Aux 3 Output	Factory Rearm Output	Ignition 3 Output	
17	Lock after Start	On	Off		
18	Lock after Shutdown	On	Off		
19	Engine Run Time (minutes)	15	10	20	25
20	Automatic Start Mode	2 hours	1 hours	Disable Start Time 1 & 2	
21	Smart Start Crank Time	Normal	Extended	Super Extended	Push Button Start
22	Smart Start Temp	Enabled	Disabled		
23	Engine Sense Mode	Smart Start	Smart Start Voltage Only	Smart Start Monitor Off	Data Port RPM Sense
24	Remote Start Program	RPM Learn/Tach	Gas Engine	Diesel Engine	
25	Ignition 2 Output Mode	Ignition 2 Output	Accessory 2 Output	Starter 2 Output	
26	Horn Honk	Normal	Long	Extra Long	
27	Turbo Timer	Disabled	Enabled		
28	Extended Parking Lights	On	Off		
29	Warn-Away Report	Enabled	Disabled		
30	CarJack Mode	Mode 1	Mode 2	Mode 3	
31	CarJack	Disabled	Enabled		
32	Data Port Trigger Inputs	Enable	Disable		
33	Galaxy System Mode	G5, A4	G2, A1		
34	Pulse ignition with unlock	Off	On		
35	Unock Before Start	Off	On		
36	Alternate Man. Trans Mode	Off	On		
37	Diesel Delay Timer(Sec)	15	10	5	

### ***Programmable System Options***

The following is a description of the programming options of the system. Some of the program branches control more than one option, and may require accessing a particular branch number twice in order to program all desired features.

1. **Arm Mode.** Selects between Manual and Passive Arming.

2. **Auto Rearming Mode.** When selected, the system will automatically re-arm 30 seconds after it is disarmed .
3. **Arming Chirps.** Selects between normal and silent operation.  
**Bypass Data Bus Module** - set Bypass module to iDataLink
4. **Ignition Door Locking / Override Code Set.** This dual program branch selects Ignition Door Locking, and programs the optional Emergency Override Code.  
Ignition Door Locking. Selects whether or not the system will automatically lock the doors 10 seconds after the ignition key is turned on.  
Override Code Set. Changes the Emergency Override Code for a higher level of security.  
**Bypass Data Bus Module** - set Bypass module to Fortin
5. **Ignition Door Unlocking.** Selects whether or not the system automatically unlocks the doors when the ignition is turned off. The Ignition Door Locking feature may be programmed to unlock all doors or the driver's door only. If driver's door only is selected, the optional Passenger Unlock wire must be connected. (*See Two Stage Door Lock Diagrams*)
6. **Door Unlock Pulse.** Selects between one pulse or two pulse operation for the door unlock output. Many new import vehicles' factory door locking systems require two pulses on the proper wire to unlock the doors. These systems can be interfaced directly without the use of relays or any additional circuitry by programming the system for double unlock pulse.
7. **Door Lock Pulse Length.** Selects between a 1, 3 or 0.1 seconds output for door locking and unlocking. Program to 3 seconds for vehicles equipped with vacuum door locking systems.
8. **Passive Door Locking.** Selects whether or not the system will automatically lock the doors during Passive Arming and Auto Rearming mode.
9. **Remote Start Confirmation Chirps.** When enabled, system chirps before starter activated. When disabled, no chirps will sound upon start.  
**Enable Auxiliary Start Activation.** Enable to use the auxiliary start feature.
10. **Ignore Open Door Report.** Bypasses the open zone warning chirps for vehicles equipped with a residual dome light circuit that remains on for a period of time after closing the door.  
**Temperature display mode:** set to Fahrenheit for 2W pager display.
11. **Auxiliary 1 Mode.** Selects from momentary, 10 second timed, or latched operation for Auxiliary 1.  
 Momentary operation provides an output for as long as the transmitter button is pressed.(1-way remote only)  
 Timed operation provides an output that turns on for 10 seconds each time the transmitter button is pressed. If the button is pressed again during the 10 seconds, the output will turn off.  
 Latched operation provides an output that turns on when the transmitter button is pressed and remains on until the transmitter button is pressed again.  
**Temperature display mode:** set to Celsius for 2W pager display.
12. **Auxiliary 2 Mode.** Selects from momentary, 10 second timed, or latched operation for Auxiliary 2.  
 Momentary operation provides an output for as long as the transmitter button is pressed.(1-way remote only)  
 Timed operation provides an output that turns on for 10 seconds each time the transmitter button is pressed. If the button is pressed again during the 10 seconds, the output will turn off.  
 Latched operation provides an output that turns on when the transmitter button is pressed and remains on until the transmitter button is pressed again.  
 Note: With the optional ScyNet network interface and Wizard software, any auxiliary function can be programmed to output for 1 second up to 255 seconds.

16. **Auxiliary 3 Output Mode.** Selects between Channel 3, Factory Rearm output, or third Ignition output.
17. **Lock After Start.** When selected, the doors will automatically lock after remote starting.
18. **Lock After Shutdown.** When selected, the doors will automatically lock after remote shutdown.
19. **Engine Run Time.** Selects between 15 or 25 minutes for the remote start run cycle.
20. **Automatic Start Mode.** Selects between every two hours or every one hour for the automatic engine starting feature.  
**Disable Start Time** Disables unit internal start time.
1. **Tachless Sense Crank Time.** Selecting engine crank time automatically selects the tachless mode and one of three crank times.  
 If the normal engine crank time is too short increase the time by selecting one of the two additional extended crank time options.  
 Normal - 0.8Sec.  
 Extended - 1.0Sec.  
 Super Extended - 1.4Sec.  
 Push Button Start - 4Sec.  
Tachless Mode. Determines the engine status using an advanced software routine, without requiring connection to the vehicle's tachometer. Tachless operation may not be compatible with some vehicles or in severe temperatures, in which case the tach wire must be connected.
22. **Smart Start Temperature Compansation.** adjusts crank time to compansate for temperature variations.
23. **Engine Sense Mode.** Enable or disable smart sense monitor, or select DataBus RPM sense.  
**DataBus RPM sense** - start the engine, enter Branch 23, Press Button 3 to learn the vehicle's tach signal. **The siren will chirp three times to confirm that the tach signal was learned. If the tach signal was not learned the siren will chirp once.**
24. **RPM Learn/Tach Monitor** This dual program branch sets the engine mode for Gas or Diesel, and learns the vehicle's RPM threshold. For installation into a diesel equipped vehicle, first set the engine type to diesel before learning RPM.  
RPM Learn/Tach Monitor. start the engine, enter Branch 24, the LED light will flash continuasly to indicate it is reading the tach signal. Press Button 1 to learn the vehicle's tach signal. The siren will chirp and the LED will flash once to confirm learning of the tach signal. The siren will chirp four times and the LED will flash four times if the tach signal was not learned.  
 Tach Monitor mode: monitors the vehicle's tach wire (or a fuel injection wire) in real-time to determine engine status and adjust starter crank time automatically.  
Gas Engine. Sets the engine type for Gasoline.  
Diesel Engine. Sets the engine type for Diesel and monitors the glow plug input to make sure the glow plugs are warm before cranking the starter. If the glow plug wire is not connected, the built-in timer waits 15 seconds before automatically cranking the starter.
25. **Ignition 2 Relay Program.** Selects one of three operating modes for the Ignition 2 relay output: Ignition 2, Accessory 2, or Starter 2.
26. **Horn Honk Mode** - Normal, Louder, Loudest.
27. **Turbo Timer.** When enabled, if the emergency brake has been applied Ignition power will be kept On for a predetermined time (2 minutes Factory Default) from the application of the emergency brake.

28. **Extended Parking Lights.** When selected, the parking lights will remain ON for 30 seconds after disarming the system.
29. **Warn-Away Pager Report.** When Enabled, Warn-Away report will be sent to the pager. If Disabled no Warn-Away report will be sent to the pager.
30. **Anti-Carjack Type.** Selects one of three modes for Anti-Carjacking: Active, Passive, or Full-Time.  
Active. When selected, while ignition is on pressing Button 4 parking light will flash once and anti-carjack feature will be engage. To disengage the Anti-Carjacking, while ignition is on press button 4 parking light will flash twice.  
Passive. When selected, the Anti-Carjacking feature will activate whenever a door is opened while the ignition is on. To disengage the Anti-Carjacking, while ignition is on press and release the valet switch parking light will flash twice.  
Full-Time. When selected, the Anti-Carjacking feature will automatically activate each time the ignition is turned on parking light will flash once , or while ignition is on and a door is opened parking light will flash once. To disengage the Anti-Carjacking, while ignition is on press and release the valet switch parking light will flash twice.

Anti-Carjack engaged: Once engaged after 90 seconds the siren will chirp and horn will honk for 15 seconds, then starter interrupt will activate, siren, horn and parking lights will turn on for 5 minutes, after 5 minutes siren and horn will turn off. starter interrupt will stay active until anti-carjack disengages.

31. **Anti-Carjack Mode.** Enables Anti-Carjacking protection.
32. **Data Port Trigger Inputs.** Enable
33. **System Mode:** Selects between G5/A4 Series or G2/A1 Series.  
 Factory Default does not affect this setting.
34. **Pulse Ignition with Unlock.** When enabled, Ignition output will pulse before door unlock command.
35. When enabled doors unlock before start.
36. **Alternate Manual Transmission Start Mode:** If set, the vehicle start mode is enabled upon engaging the hand brake. **(manual transmission systems only).**

Start History	LED Blink
Transmitter	1
2 way Transmitter	2
Auto Start Temp	3
Auto Start Timer	4
Mobilink	5
External Trigger	6

# Relay Diagrams

Positive Dome Light Activation

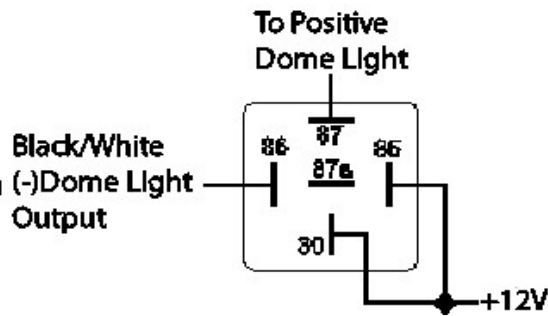

Negative Dome Light Activation

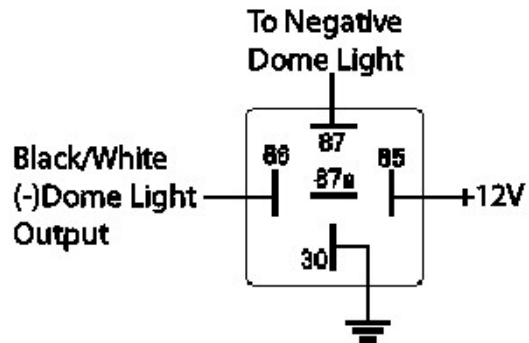

Positive Horn Honk

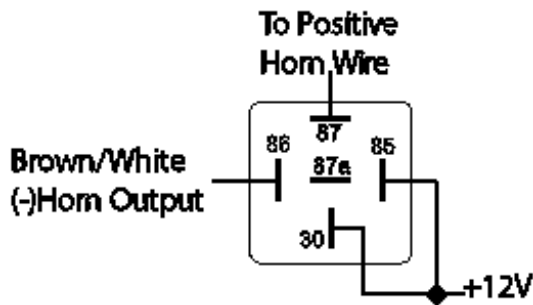

Negative Horn Honk

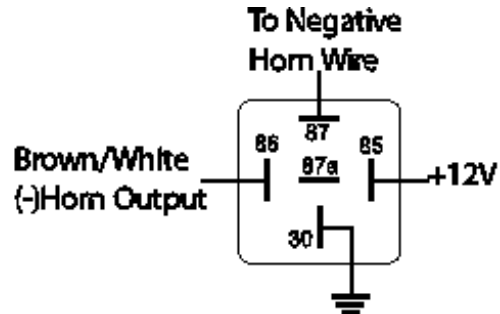

## OPEN CIRCUIT CLUTCH SWITCH

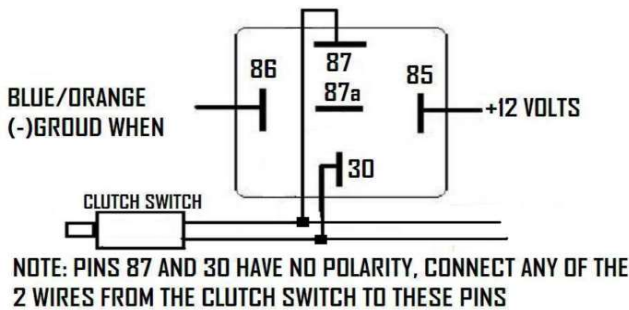

Starter Defeat/Anti-Grind

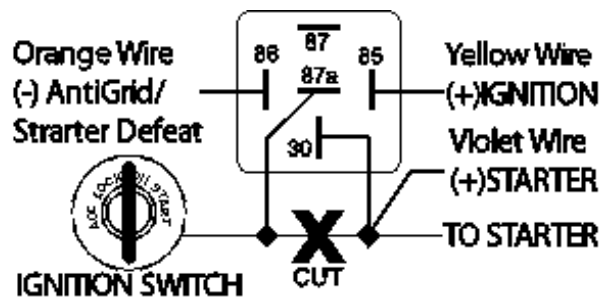

## CLOSED CIRCUIT CLUTCH SWITCH

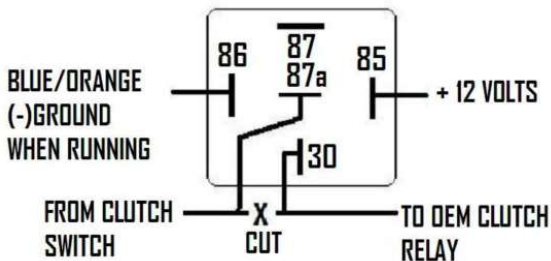

Negative Glow Plug

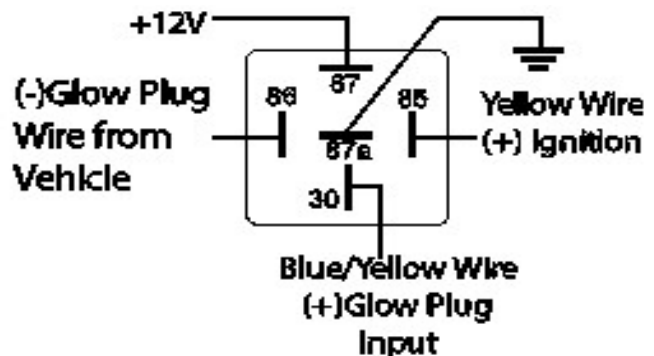

# Door Lock Diagrams

Follow the diagrams below for connecting basic door lock systems. For Two Stage door lock systems (separately unlocks driver and passenger doors) see following pages.

## Negative Trigger

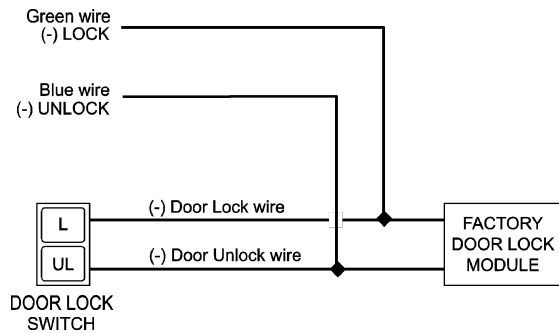

## Positive Trigger

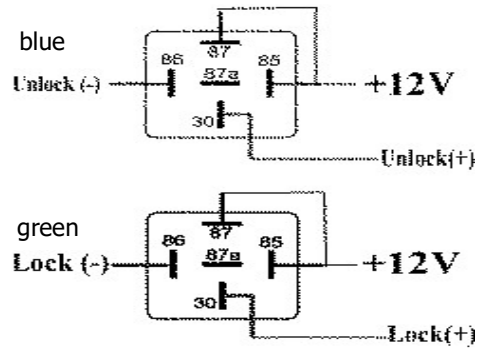

## Reverse Polarity

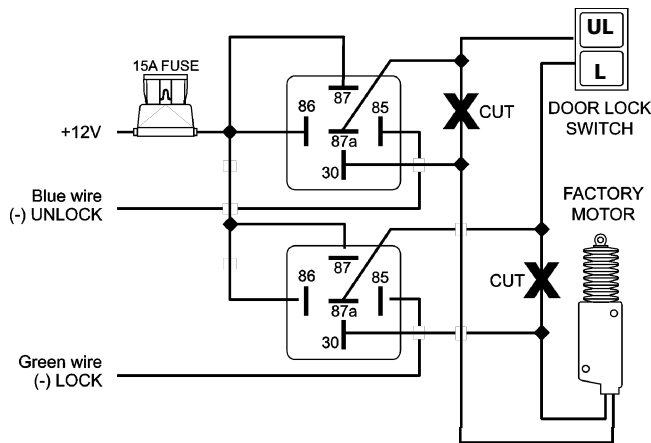

## Vacuum

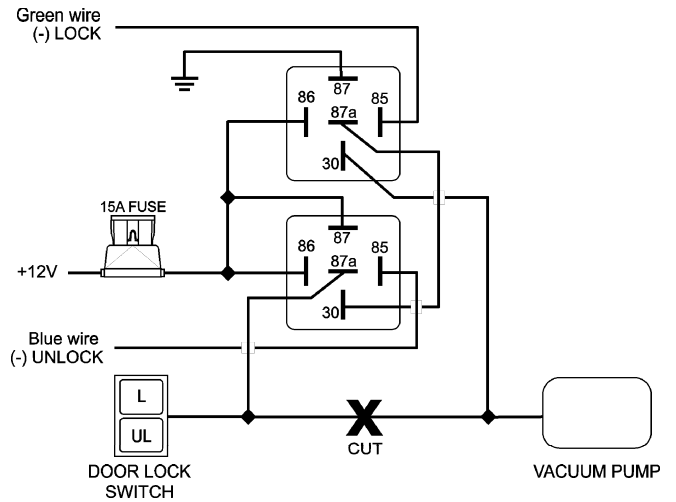

## Adding Actuators

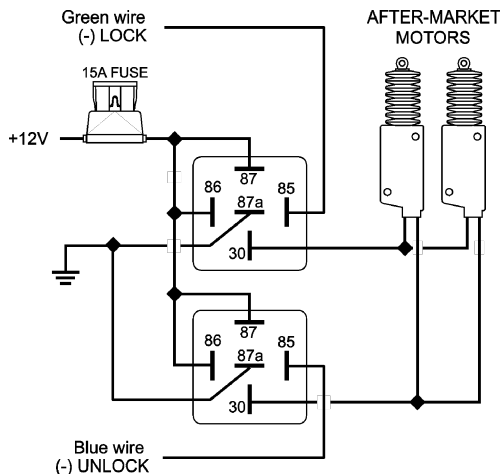



# Two Stage Door Lock Diagrams

The Galaxy 5000/2000RS-DBP Series is equipped with a dedicated Passenger Unlock output allowing Two Stage Door Lock operation. When connected as shown below, disarming the system will unlock only the driver's door. Pressing the disarm button again will unlock all doors.

## Two Stage Negative Trigger

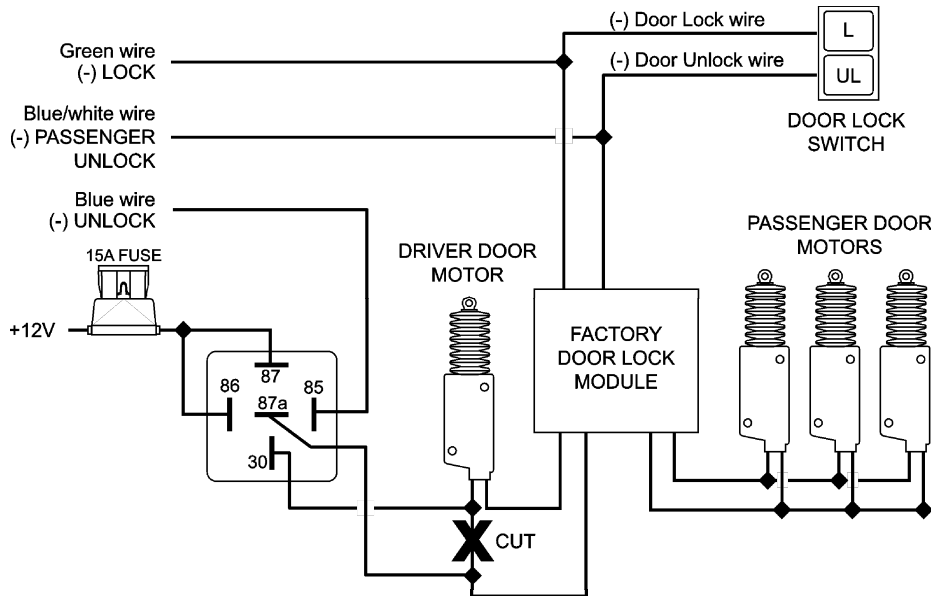

## Two Stage Positive Trigger

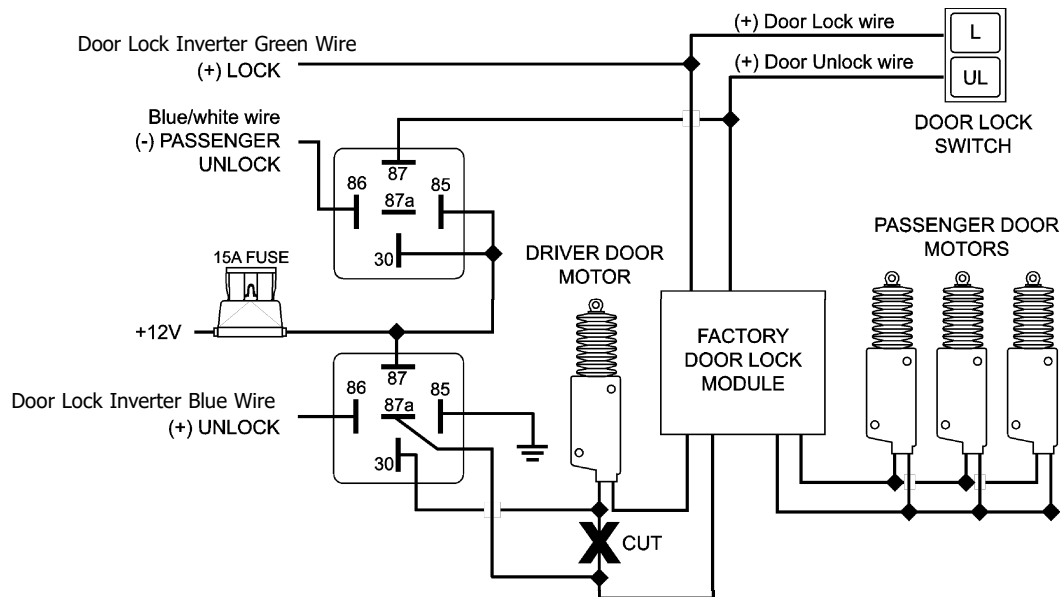

# Two Stage Door Lock Diagrams cont'd

## Two Stage Reverse Polarity

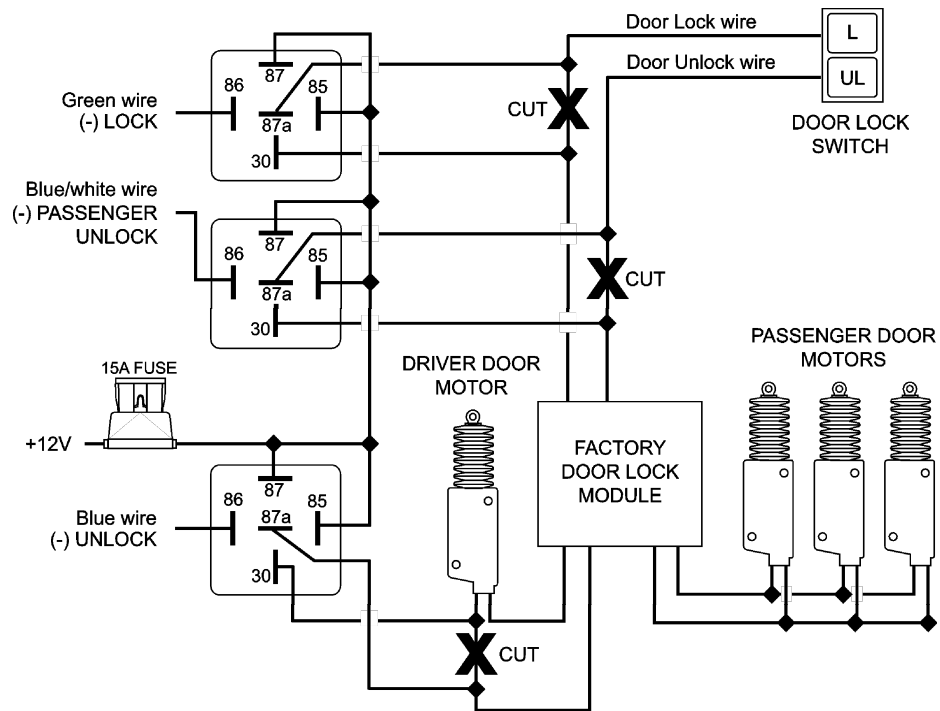

## Two Stage Adding Actuators

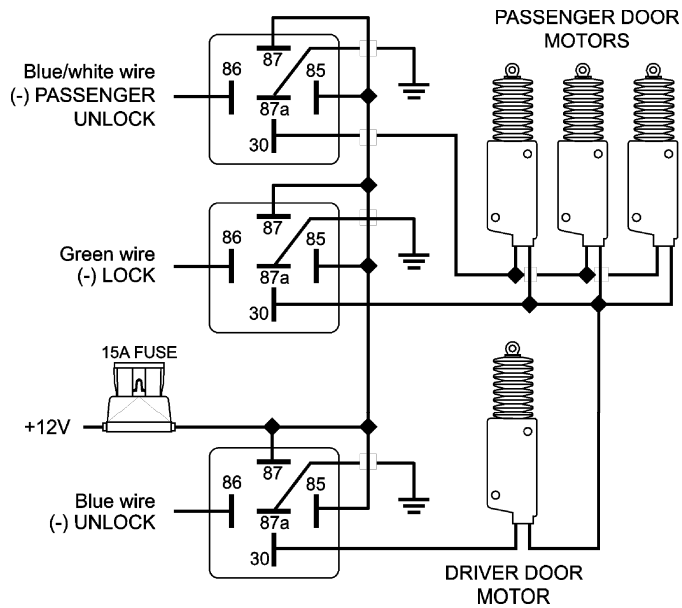

## Technical Information

### FCC ID: OARRXAM2000

This device complies with Part 15 of FCC Rules.

Operation is subject to the following two conditions:

- 1) This device may not cause harmful interference.
- 2) This device must accept any interference received, including interference that may cause undesired operation

### Built-in LED Light/Override/Valet/Call Switch into the Antenna

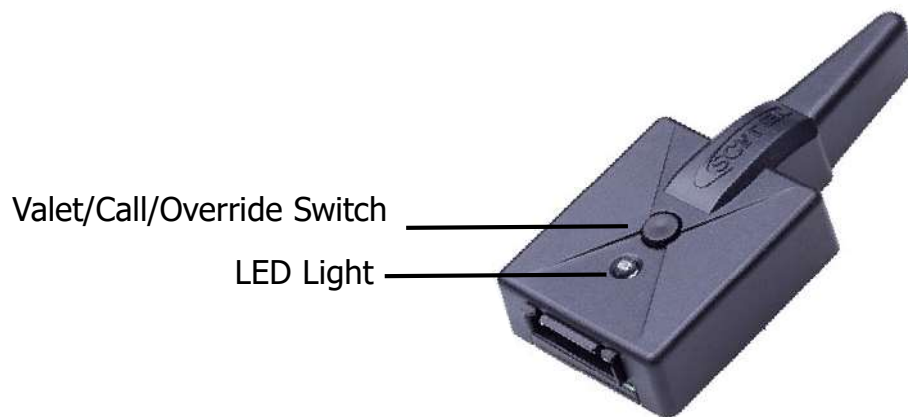

## Starter Diagnostics

Starter doesn't start and parking lights flash:

- 3 Times - **Engine RPM not detected (check tach wire and/or perform tach learn procedure)**  
**Hood Trigger is active (hood is open, wire is shorted to ground or pin switch is defective)**
- 5 Times - **Unit is in Valet (service) mode, and start is disabled.**
- 6 Times - **Emergency Brake Disengaged ( Manual Transmission )**
- 7 Times - **Remote start not ready ( Manual Transmission )**
- 8 Times - **Brake Trigger is active ( Brake switch input is shorted to ground or incorrect)**

# Wiring Diagram

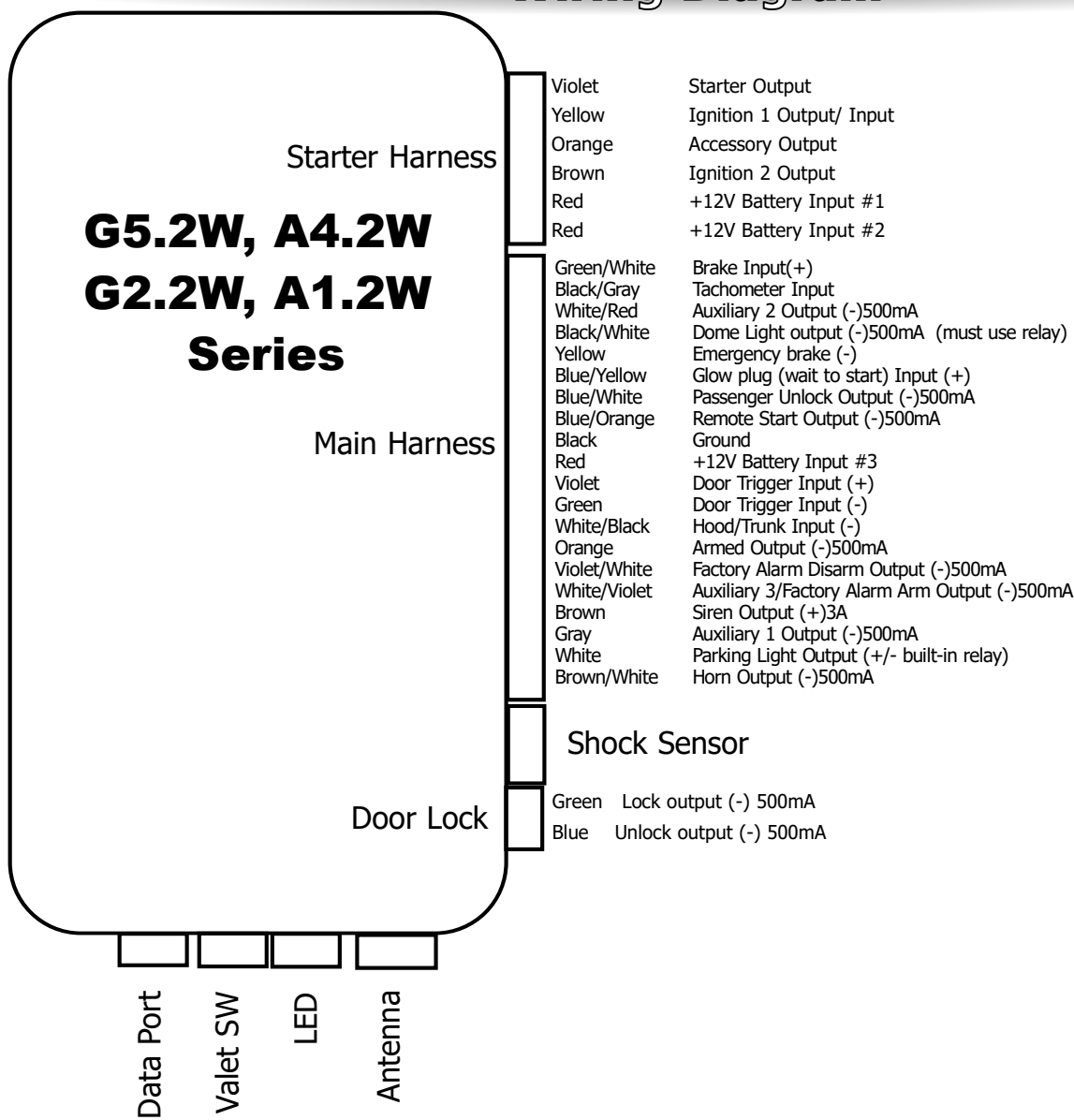

For Manual Transmission:

Must Install System Made For Manual Transmission:

**G5-M and G2-M**

For Manual Transmission, These wires Must be connected : Tachometer input , Emergency Brake and Door Trigger

**ScyTek Electronics**

11627 Cantara Street  
North Hollywood, CA 91605  
www.scytek.net